



Installation Instructions & Owner's Manual

## Evolve ES Series®

*Water Softeners*



**For Models:**

- ES-844
- ES-948
- ES-1044
- ES-1248
- ES-1354

# TABLE OF CONTENTS

<b>Preinstallation Instructions for Dealers</b> .....	3
<b>Bypass Valve</b> .....	4
<b>Installation</b> .....	5-6
<b>Programming Procedures</b> .....	7-8
<b>Operating Displays and Instructions</b> .....	9-10
<b>Start-up Instructions</b> .....	11-12
<b>Troubleshooting Guide</b> .....	13-16
<b>Replacement Parts</b> .....	17-25
<b>Specifications</b> .....	26
<b>Warranty</b> .....	27
<b>Quick Reference Guide</b> .....	28

## **YOUR WATER TEST**

Hardness \_\_\_\_\_ gpg  
Iron \_\_\_\_\_ ppm  
pH \_\_\_\_\_ number  
\*Nitrates \_\_\_\_\_ ppm  
Manganese \_\_\_\_\_ ppm  
Sulphur \_\_\_\_\_ yes/no  
Total Dissolved Solids \_\_\_\_\_

\*Over 10 ppm may be harmful for human consumption.  
Water conditioners do not remove nitrates or coliform bacteria,  
this requires specialized equipment.

Your Evolve Series water softeners are precision built, high quality products. These units will deliver conditioned water for many years to come, when installed and operated properly. Please study this manual carefully and understand the cautions and notes before installing. This manual should be kept for future reference. If you have any questions regarding your water softener, contact your local dealer or the manufacturer at the following:

**1900 Prospect Court • Appleton, WI 54914**  
**Phone: 920-739-9401 • Fax: 920-739-9406**

## PREINSTALLATION INSTRUCTIONS FOR DEALERS:

The manufacturer has preset the water treatment unit's sequence of cycles, cycle times, salt dose, exchange capacity and salt dose refill time.

**The dealer** should read this page and guide the installer regarding hardness, day override, time of regeneration, service alarm and buzzer alarm settings before installation.

**For the installer**, the following must be used:

- Program Installer Settings ... Hardness, Day Override (preset to 6 days), Time of Regeneration (preset to 2 a.m., with brine tank refill to occur four hours prior; see Operating Displays and Instructions for more details), Service Alarms (preset to "OFF") and Buzzer Alarm (preset to start at 6 a.m. and end at 10 p.m.)
- Read Normal Operating Displays
- Set Time of Day
- Read Power Loss & Error Display
- Be sure system and installation are in compliance with all state and local laws and regulations.

**For the homeowner**, please read Programming Procedures and Operating Displays and Instructions.

During operation, the normal user display is *time of day* and *gallons per minute*.

*Flow Rate*, *Vacation Mode*, *Capacity Remaining* and *Days to a Regeneration* are optional displays but are not normally used. (Vacation Mode is used only when there will be no water usage for an extended period of time. Once 50 gallons of water is used, the unit will automatically regenerate that night and resume normal operation.) Each of these can be viewed by pressing **NEXT** to scroll through them. When stepping through any programming, if no buttons are pressed within 5 minutes, the display returns to a normal user display. Any changes made prior to the 5 minute time out are incorporated. To quickly exit any Programming, Installer Settings, etc., press **SET CLOCK**. Any changes made prior to the exit are incorporated.

If desired, two regenerations within 24 hours are possible with a return to the preset program.

To do a *double regeneration*:

1. Press the **REGEN** button once. "REGEN TODAY" will flash on the display.
2. Press and hold the **REGEN** button for three seconds until a regeneration begins.

Once the valve has completed the immediate regeneration, the valve will regenerate one more time at the preset.

# BYPASS VALVE:

The bypass valve is typically used to isolate the control valve from the plumbing system's water pressure in order to perform control valve repairs or maintenance. The 1" full flow bypass valve incorporates four positions, including a diagnostic position that allows a service technician to have pressure to test a system while providing untreated bypass water to the building. Be sure to install bypass valve onto main control valve, before beginning plumbing. Or, make provisions in the plumbing system for a bypass. The bypass body and rotors are glass-filled Noryl® and the nuts and caps are glass-filled polypropylene. All seals are self-lubricating EPDM to help prevent valve seizing after long periods of non-use. Internal "O" Rings can easily be replaced if service is required.

The bypass consists of two interchangeable plug valves that are operated independently by red arrow shaped handles. The handles identify the direction of flow. The plug valves enable the bypass valve to operate in four positions.

1. **NORMAL OPERATION POSITION:** The inlet and outlet handles point in the direction of flow indicated by the engraved arrows on the control valve. Water flows through the control valve for normal operation of a water softener. During the regeneration cycle this position provides regeneration water to the unit, while also providing untreated water to the distribution system (**Fig. 1**).
2. **BYPASS POSITION:** The inlet and outlet handles point to the center of the bypass. The system is isolated from the water pressure in the plumbing system. Untreated water is supplied to the building (**Fig. 2**).
3. **DIAGNOSTIC POSITION:** The inlet handle points toward the control valve and the outlet handle points to the center of bypass valve. Untreated supply water is allowed to flow to the system and to the building, while not allowing water to exit from the system to the building (**Fig. 3**). This allows the service technician to draw brine and perform other tests without the test water going to the building.

**NOTE:** The system must be rinsed before returning the bypass valve to the normal position.

4. **SHUT OFF POSITION:** The inlet handle points to the center of the bypass valve and the outlet handle points away from the control valve. The water is shut off to the building. The water treatment system will depressurize upon opening a tap in the building. A negative pressure in the building combined with the softener being in regeneration could cause a siphoning of brine into the building. If water is available on the outlet side of the softener, it is an indication of water bypassing the system (**Fig. 4**) (i.e. a plumbing cross-connection somewhere in the building).

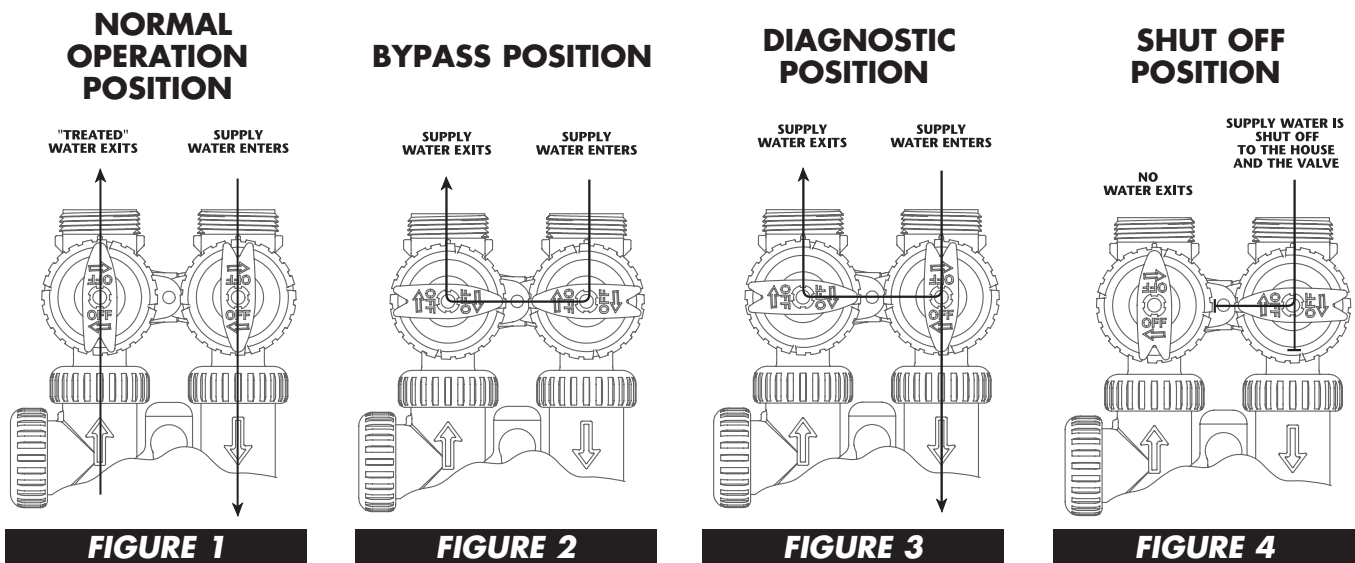

# INSTALLATION:

## GENERAL INSTALLATION & SERVICE WARNINGS

The control valve, fittings and/or bypass are designed to accommodate minor plumbing misalignments. There is a small amount of "give" to properly connect the piping, but the water softener is not designed to support the weight of the plumbing.

Do not use Vaseline, oils, other hydrocarbon lubricants or spray silicone anywhere. A silicone lubricant may be used on black "O" Rings, but is not necessary. Avoid any type of lubricants, including silicone, on red or clear lip seals.

Do not use pipe dope or other sealants on threads. Teflon® tape must be used on the threads of the 1" NPT inlet and outlet, the brine line connection at the control valve, and on the threads for the drain line connection. Teflon® tape is not used on the nut connections or caps because "O" Ring seals are used. The nuts and caps are designed to be unscrewed or tightened by hand or with the special plastic Service Wrench, #CV3193-02. If necessary pliers can be used to unscrew the nut or cap. Do not use a pipe wrench to tighten nuts or caps. Do not place screwdriver in slots on caps and/or tap with a hammer.

## SITE REQUIREMENTS

- water pressure – 25-100 psi
- water temperature – 33-100°F (0.5-37.7°C)
- electrical – 115/120V, 60Hz uninterrupted outlet
- current draw is 0.5 amperes
- the plug-in transformer is for dry locations only
- the tank should be on a firm level surface

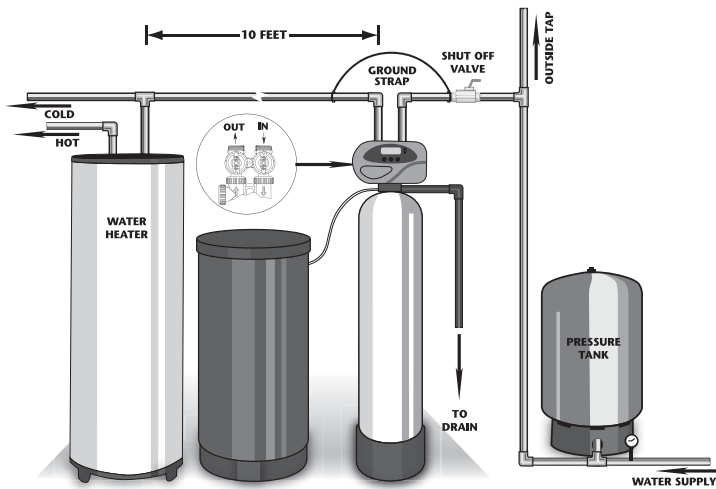

**WELL WATER INSTALLATION**

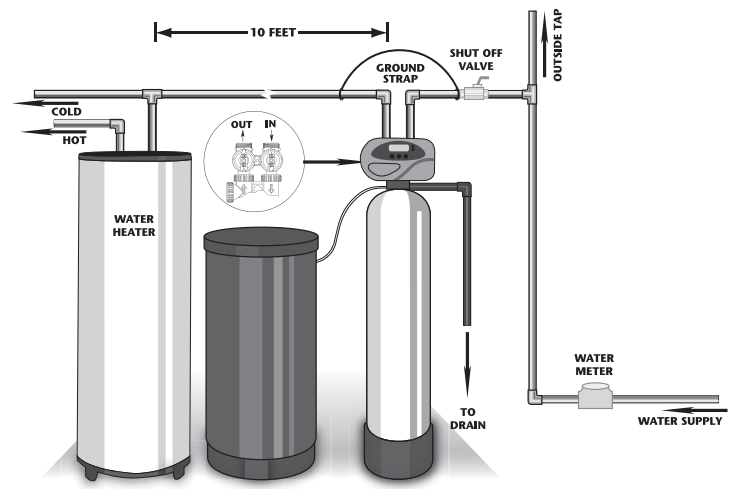

**MUNICIPAL INSTALLATION**

1. The distance between the drain and the water conditioner should be as short as possible.
2. Since salt must be periodically added to the brine tank, it should be located where it is easily accessible.
3. Do not install any water conditioner with less than 10 feet of piping between its outlet and the inlet of a water heater.
4. Do not locate unit where it or its connections (including the drain and overflow lines) will ever be subjected to room temperatures under 33°F.
5. Do not subject the tank to any vacuum, as this may cause an "implosion" and could result in leaking. If there is a possibility a vacuum could occur, please make provision for a vacuum breaker in the installation.
6. **INLET/OUTLET PLUMBING:** Be sure to install Bypass Valve onto main control valve before beginning plumbing. Make provisions to bypass outside hydrant and cold hard water lines at this time. Install an inlet shutoff valve and plumb to the unit's bypass valve inlet located at the right rear as you face the unit. There are a variety of installation fittings available. They are listed under Installation Fitting Assemblies, page 26-27. When assembling the installation fitting package (inlet and outlet), connect the fitting to the plumbing system first and then attach the nut, split ring and "O" Ring. Heat from soldering or solvent cements may damage the nut, split ring or "O" Ring. Solder joints should be cool and solvent cements should be set before installing the nut, split ring and "O" Ring. Avoid getting solder flux, primer, and solvent cement on any part of the "O" Rings, split rings, bypass valve or control valve. If the building's electrical system is grounded to the plumbing, install a copper grounding strap from the inlet to the outlet pipe. Plumbing must be done in accordance with all applicable local codes.

7. **INSTALLING GROUND:** To maintain an electrical ground in metal plumbing of a home's cold water piping (such as a copper plumbing system), install a ground clamp or jumper wiring.

**NOTE:** If replacing an existing softener, also replace the ground clamps/wire. If removing a softener, replace the piping with the same type of piping as the original to assure plumbing integrity and grounding.

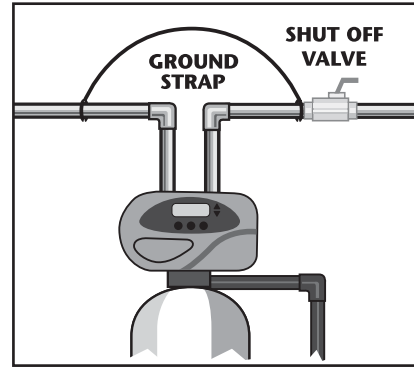

8. **DRAIN LINE:** First, be sure that the drain can handle the backwash rate of the system. Solder joints near the drain must be done prior to connecting the drain line flow control fitting. Leave at least 6" between the drain line flow control fitting and solder joints. Failure to do this could cause interior damage to the flow control. Install a 1/2" I.D. flexible plastic tube to the Drain Line Assembly or discard the tubing nut and use the 3/4" NPT fitting for rigid pipe (recommended). **If the backwash rate is greater than 7 gpm, use a 3/4" rigid drain line.** Where the drain line is elevated but empties into a drain below the level of the control valve, form a 7" loop at the discharge end of the line so that the bottom of the loop is level with the drain connection on the control valve. This will provide an adequate anti-siphon trap. Piping the drain line overhead <10 ft is normally not a problem. Be sure adequate pressure is available (40-60 psi is recommended). Where the drain empties into an overhead sewer line, a sink-type trap must be used. Run drain tube to its discharge point in accordance with plumbing codes. Pay special attention to codes for air gaps and anti-siphon devices.

**NOTE:** Drain line nut will not be supplied for units having a backwash rate greater than 7 gpm.

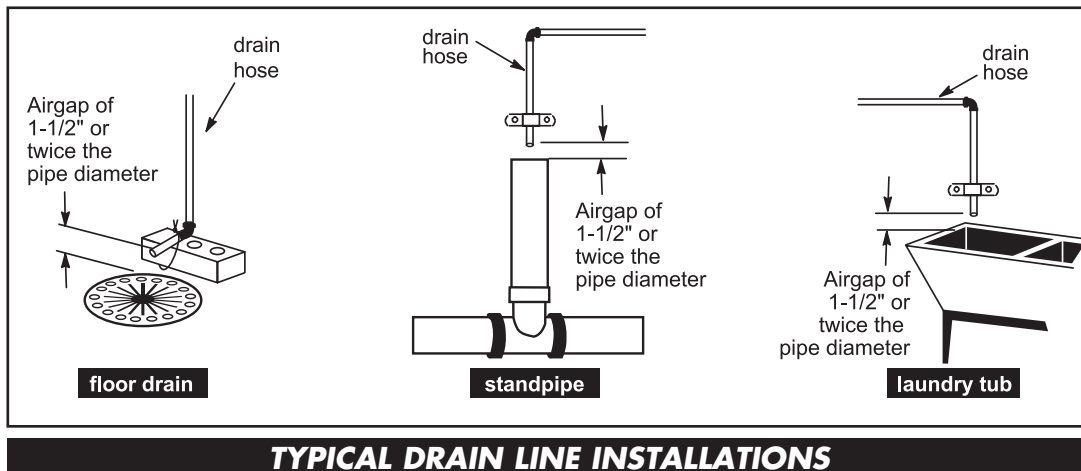

9. **BRINE TANK CONNECTION:** Install the 3/8" O.D. polyethylene tube from the Refill Elbow to the Brine Valve in the brine tank.
10. **OVERFLOW LINE CONNECTION:** An overflow drain line is recommended where a brine overflow could damage furnishings or the building structure. Your softener is equipped with a brine tank safety float which greatly reduces the chance of an accidental brine overflow. In the event of a malfunction, however, an overflow line connection will direct the "overflow" to the drain instead of spilling on the floor where it could cause considerable damage. This fitting is an elbow on the side of the brine tank. Attach a length of 1/2" I.D. tubing to fitting and run to drain. Do not elevate overflow line higher than 3" below bottom of overflow fitting. Do not "tie" this tube into the drain line of the control valve. Overflow line must be a direct, separate line from overflow fitting to drain, sewer, or tub. Allow an air gap as per the drain line instructions.



**CAUTION:** Never insert a drain line into a drain, sewer line, or trap. Always allow an air gap between the drain line and the wastewater to prevent the possibility of sewage being back-siphoned into the conditioner.

# PROGRAMMING PROCEDURES:

## 1. Set time of day:

Time of day should only need to be set after extended power outages or when daylight saving time begins or ends. If an extended power outage occurs, the time of day will flash on and off indicating that the time should be reset.

**STEP 1** – Press **CLOCK**.

**STEP 2** – **CURRENT TIME (HOUR)**: Set the hour of the day using **+** or **-** buttons. AM/PM toggles after 12. Press **NEXT** to go to step 3.

**STEP 3** – **CURRENT TIME (MINUTES)**: Set the minutes using **+** or **-** buttons. If it is desired to back up to the previous step press **REGEN** button once. Pressing **NEXT** will exit **CLOCK** and return to the general operating display (page 9).



## 2. Programming:

**NOTE:** The manufacturer has preset the unit so that the gallons between regenerations will be automatically calculated after the hardness is entered.

**STEP 1** – Press **NEXT** and **+** simultaneously for 3 seconds.

**STEP 2** – **HARDNESS**: Set the amount of hardness in grains per gallon (default 20) using the **+** or **-** buttons. The allowable range is from 1 to 150 in 1 grain increments.

**NOTE:** If a resin media is used in the softener, increase the grains per gallon if soluble iron is present (1 ppm = 4 gpg). This display will show “-nA- (not available)” if “FILTER” is selected or if “AUTO” is not factory set.

Press **NEXT** to go to step 3.

Press **REGEN** if you want to exit.

**STEP 3** – **DAY OVERRIDE**: The manufacturer has factory set 12 DAYS as the default. This is the maximum number of days between regenerations. If this is set to “OFF”, regeneration initiation is based solely on gallons used. If any number is set (allowable range from 1 to 28), a regeneration initiation will be called for on that day even if a sufficient number of gallons were not used to call for a regeneration.

Set Day Override using **+** or **-** buttons (12 is recommended):

- set number of days between regeneration (1 to 28); or
- set to “OFF”.

Press **NEXT** to go to step 4.

Press **REGEN** if you need to return to the previous step.

**STEP 4** – **REGENERATION HOUR**: The manufacturer has factory set 2:00 A.M. as the default. This is the hour of day for regeneration and can be reset by using **+** or **-** buttons. “AM/PM” toggles after 12. The default time is 2:00 a.m. (recommended for a normal household).

Press **NEXT** to go to step 5.

Press **REGEN** if you need to return to the previous step.

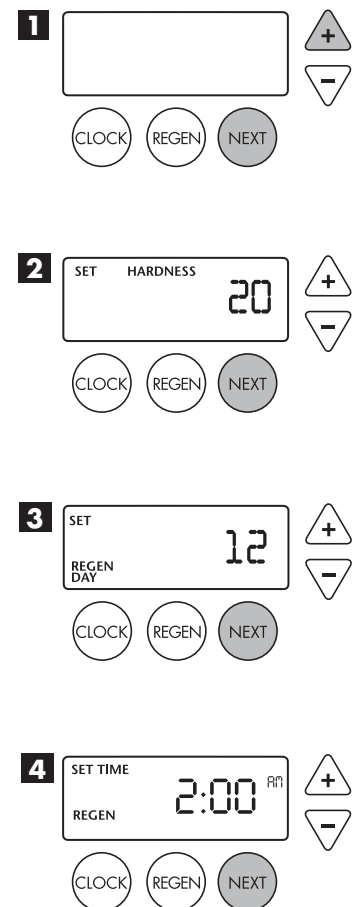

**STEP 5 – REGENERATION MINUTES:** Set the minutes using **+** or **-** buttons. Press **NEXT** to exit installer programming. Press **REGEN** if you need to return to the previous step. To initiate an immediate manual regeneration, press and hold the **REGEN** button for three seconds. The system will begin to regenerate immediately. The control may be manually stepped through the regeneration cycles by pressing **REGEN**.



**STEP 6 – BACKLIGHT DISPLAY CONTROL:** Set the display backlight on or off using **+** or **-** buttons. In the OFF position, the backlight will turn off after 5 minutes of inactivity.

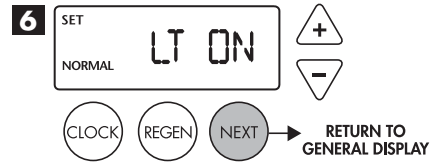

# OPERATING DISPLAYS AND INSTRUCTIONS:

1. **GENERAL OPERATION:** When the system is operating, one of three displays may be shown. Pressing **NEXT** will alternate between the displays. One of the displays is always the current time of day. The second display shows the current treated water flow rate through the system in Gallons Per Minute. The third display is one of the following: days remaining or volume remaining. Days remaining is the number of days left before the system goes through a regeneration cycle. Capacity remaining is the gallons that will be treated before the system goes through a regeneration cycle. The user can scroll between the displays as desired.

If a water meter is installed, the word "Softening" or "Filtering" flashes on the display when water is being treated (i.e. water is flowing through the system).

## GENERAL OPERATION DISPLAYS

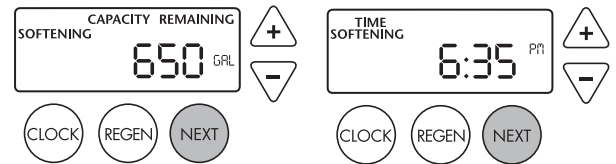

2. **REGENERATION MODE:** Typically a system is set to regenerate at a time of no water use. If there is a demand for water when the system is regenerating, untreated water will be delivered. When the system begins to regenerate, the display will change to include information about the step of the regeneration process and the time remaining for that step to be completed. The system runs through the steps automatically and will reset itself to provide treated water when the regeneration has been completed.
3. **MANUAL REGENERATION:** Sometimes there is a need to regenerate before the control valve calls for it. This may be needed if a period of heavy water use is anticipated or when the system has been operated without salt.
  - To initiate a manual regeneration *at the next preset regeneration time*, press and release **REGEN**. The words "REGEN TODAY" will flash on the display to indicate that the system will regenerate at the next regeneration time (set in Programming, steps 4 and 5). *If you pressed the REGEN button in error, pressing the button again will cancel the command.*
  - To initiate a manual regeneration *immediately*, press and hold the **REGEN** button for three seconds. The system will begin to regenerate immediately. **This command cannot be cancelled.**

## REGENERATION MODE



## MANUAL REGENERATION

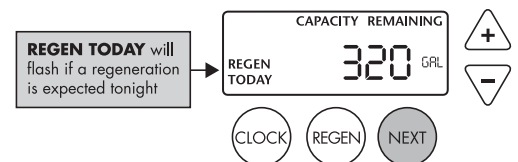

Once a manual regeneration is initiated, the unit will go into the FILL position. This position allows water to enter the brine tank until it reaches the proper level. Once this position is complete, you will notice a 240 Minute (4 hours) SOFTENING position. This 4-hour window allows the salt to dissolve and achieve proper brine strength. During these FILL and SOFTENING positions, you will have softened water available for use. Once the unit advances to the BACKWASH position and subsequent positions thereafter (see Start Up Instructions for regeneration sequence), the water softener will deliver water, but it will be untreated.

**IMPORTANT:** With the Dry Salt Storage Feature, the brine tank will refill 4 hours before the actual regeneration occurs. You may experience a small amount of noise for a short period of time at 10:00 p.m. (with typical setting) on the night that regeneration is to occur. This noise is only the brine tank filling and at no time during this process will you be without treated water.

4. **POWER LOSS AND BATTERY REPLACEMENT:** The AC transformer comes with a 15 foot power cord and is designed for use with the control valve; the transformer should only be used in a dry location.

In the event of a power outage that is less than 24 hours, the control valve will remember all settings and time of day. After 24 hours, the only item that needs to be reset is the time of day and will be indicated by the time of day flashing. All other settings are permanently stored in the nonvolatile memory.

If a power loss occurs that is *less than 24 hours and the time of day flashes*, this indicates that the battery is depleted. The time of day should be reset and the non-rechargeable battery should be replaced. The battery is a 3 Volt Lithium Coin Cell type 2032 and is readily available at most stores. To access battery location, remove front cover (see diagram on page 14 for battery location).

## BATTERY REPLACEMENT

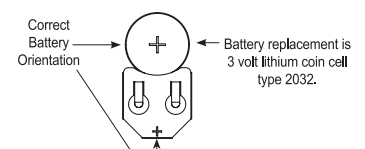

When replacing the battery, align positives and push down to fully seat.

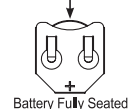

5. **ERROR MESSAGE:** If the word "ERROR" and a number are alternately flashing on the display record the number and contact the dealer for help. This indicates that the control valve was not able to function properly.

6. **BRINE TANK MAINTENANCE AND SALT:** Refill the brine tank as necessary, making sure at least 1/3 of the brine tank is full at all times. Without proper salt levels, the water softener may not operate properly.

Because "typical" settings of this water softener include a dry salt storage feature (no water in brine tank between regeneration), the manufacturer recommends the use of solar salt for best results. The brine tank is manufactured for the use of solar, pellets or rock salt. **Do not use block salt.** If pellet or rock salt is used, a cleaning of the brine tank every six months is recommended. If the dry salt storage feature is not being utilized, block salt may be used.

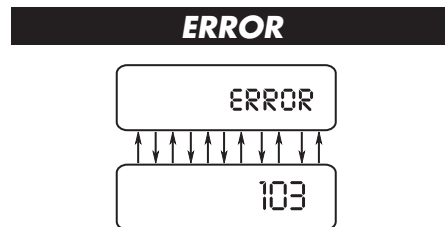

**CAUTION:** *With some models the manufacturer does NOT recommend the use of any resin cleaners, nor placing any resin cleaners into the brine tank. Furthermore, do not use any salt that indicates it is an iron cleaning salt or that contains any cleaning additives. This may be harmful to the water softener and for human consumption. Consult dealer for proper cleaning instructions and agents.*

# START-UP INSTRUCTIONS:

## FLUSHING OF SYSTEM:

To flush the system of any debris and air after installation is complete, please perform the following steps:

1. Rotate bypass handles to the bypass mode (see Fig. 2 of page 4).
2. Turn on inlet water and check for leaks in the newly installed plumbing.
3. Fully open a cold water faucet, preferable at a laundry sink or bathtub without an aerator.
4. Wait two to three minutes or until water runs clear, then turn water off and follow start-up instructions.

System regeneration sequence is in the following order. (If it is desired to change this sequence, please refer to the Dealer Manual or contact the manufacturer.)

- 1) **BRINE TANK REFILL**
- 2) **4 HOURS (240 minutes) OF SOFTENING MODE WHILE SALT IS DISSOLVING**
- 3) **BACKWASH**
- 4) **BRINE DRAW AND SLOW RINSE**
- 5) **FAST RINSE**
- 6) **END (return to service)**

The system is now ready for filling with water and for testing.

1. With the softener in the bypass mode (**Fig. 2 on page 4**) and the control valve in normal operation where the display shows either the time of day or the gallons remaining, manually add 3" of water to the regenerant tank.

**NOTE:** If too much water is put into the brine tank during softener start up, it could result in a "salty water" complaint after the first regeneration.

During the first regeneration the unit will draw out the initial volume of brine/regenerant and refill it with the correct preset amount.

2. With the softener in bypass mode, press and hold the **REGEN** button until the motor starts. Release button. The display reads "FILL" and the remaining time in this step is counting down. Since the regenerant tank was already filled in Step 1 press **REGEN** again and the display will read SOFTENING 240 (During a full regeneration this will be a 4 hour period for salt to dissolve). Press **REGEN** again to put the valve into "BACKWASH." Once valve has stopped in position, unplug the transformer so that the valve will not cycle to the next position. Open the inlet handle of the bypass valve very slightly allowing water to fill the tank slowly in order to expel air.



**CAUTION: If water flows too rapidly, there will be a loss of media to the drain.**

3. When the water is flowing steadily to the drain without the presence of air, slowly open the inlet valve. Restore power and momentarily press the **REGEN** button to advance the control to the "BRINE" position.
4. The bypass is now in the diagnostic mode (**Fig. 3 on page 4**). Check to verify that water is being drawn from regenerant tank with no air leaks or bubbles in the brine line. There should be a slow flow to the drain.
5. Momentarily press **REGEN** again until the display reads "RINSE." There should be a rapid flow to the drain. Unplug transformer to keep the valve in the "RINSE" position. Allow to run until steady, clear and without air. While the unit is rinsing, load the brine tank with water softener salt (**refer to page 9, Brine Tank Maintenance and Salt**). Restore power.
6. Place bypass valve in the normal operating mode (**Fig. 1 on page 4**) by opening the outlet bypass handle. Press **REGEN** and the unit will return to the service position with time of day being displayed.

## 7. **CONDITIONING OF MEDIA:**

To flush any remaining debris and air from the system again:

1. Full open a cold water faucet, preferably at a laundry sink or bathtub without an aerator.
2. Wait two to three minutes or until water runs clear, then turn water off.
3. Turn on hot water and check for air, then turn water off after air is discharged.

8. **SANITIZING OF UNIT UPON INSTALLATION AND AFTER SERVICE:**

At this time, it is advised to sanitize the softener:

1. Open brine tank and remove brine well cover.
2. Pour 1 oz. of household bleach into the softener brine well.
3. Replace brine well cover.

**NOTE:** Avoid pouring bleach directly onto the safety float components in the brine well.

Unit sanitizing will be complete when the first cycle is run and the bleach is flushed from the softener.

9. Check time of day. Start-up is now complete.

# TROUBLESHOOTING GUIDE:

PROBLEM	CAUSE	CORRECTION
<b>1. No display on PC board</b>	A. No power at electric outlet	A. Repair outlet or use working outlet
	B. Control valve power adapter not plugged into outlet or power cord end not connected to PC board connection	B. Plug power adapter into outlet or connect power cord end to PC board connection
	C. Improper power supply	C. Verify proper voltage is being delivered to PC board
	D. Defective power adapter	D. Replace power adapter
	E. Defective PC board	E. Replace PC board
	F. Dead battery	F. Replace battery
<b>2. PC board does not display correct time of day</b>	A. Power adapter plugged into electric outlet controlled by light switch	A. Use uninterrupted outlet
	B. Tripped breaker switch and/or tripped GFI	B. Reset breaker switch and/or GFI switch
	C. Power outage	C. Reset time of day. If PC board has battery back up present the battery may be depleted. See front cover and drive assembly drawing for instructions.
	D. Defective PC board	D. Replace PC board
<b>3. Display does not indicate that water is flowing. Refer to user instructions for how the display indicates water is flowing.</b>	A. Bypass valve in bypass position	A. Turn bypass handles to place bypass in service position
	B. Meter is not connected to meter connection on PC board	B. Connect meter to three pin connection labeled METER on PC board
	C. Restricted/stalled meter turbine	C. Remove meter and check for rotation or foreign material
	D. Meter wire not installed securely into three pin connector	D. Verify meter cable wires are installed securely into three pin connector labeled METER
	E. Defective meter	E. Replace meter
	F. Defective PC board	F. Replace PC board
<b>4. Control valve regenerates at wrong time of day</b>	A. Power outage	A. Reset time of day. If PC board has battery back up present the battery may be depleted. See front cover and drive assembly drawing for instructions.
	B. Time of day not set correctly	B. Reset to correct time of day
	C. Time of regeneration set incorrectly	C. Reset regeneration time
	D. Control valve set at "on 0" (immediate regeneration)	D. Check programming setting and reset to NORMAL (for a delayed regen time)
	E. Control valve set at "NORMAL + on 0" (delayed and/or immediate)	E. Check programming setting and reset to NORMAL (for a delayed regen time)
<b>5. Time of day flashes on and off</b>	A. Power outage	A. Reset time of day. If PC board has battery back up present the battery may be depleted. See front cover and drive assembly drawing for instructions.
<b>6. Control valve does not regenerate automatically when the correct button(s) is depressed and held. For timeclock valves the buttons are ▲ &amp; ▼. For all other valves the button is REGEN.</b>	A. Broken drive gear or drive cap assembly	A. Replace drive gear or drive cap assembly
	B. Broken piston rod	B. Replace piston rod
	C. Defective PC board	C. Defective PC board

# TROUBLESHOOTING GUIDE *cont'd:*

<b>PROBLEM</b>	<b>CAUSE</b>	<b>CORRECTION</b>
<b>7. Control valve does not regenerate automatically but does when the correct button(s) is depressed and held. For timeclock valves the buttons are ▲ &amp; ▼. For all other valves the button is REGEN.</b>	A. Bypass valve in bypass position	A. Turn bypass handles to place bypass in service position
	B. Meter is not connected to meter connection on PC board	B. Connect meter to three pin connection labeled METER on PC board
	C. Restricted/stalled meter turbine	C. Remove meter and check for rotation or foreign material
	D. Incorrect programming	D. Check for programming error
	E. Meter wire not installed securely into three pin connector	E. Verify meter cable wires are installed securely into three pin connector labeled METER
	F. Defective meter	F. Replace meter
	G. Defective PC board	G. Replace PC board
<b>8. Hard or untreated water is being delivered</b>	A. Bypass valve is open or faulty	A. Fully close bypass valve or replace
	B. Media is exhausted due to high water usage	B. Check program settings or diagnostics for abnormal water usage
	C. Meter not registering	C. Remove meter and check for rotation or foreign material
	D. Water quality fluctuation	D. Test water and adjust program values accordingly
	E. No regenerant or low level of regenerant in regenerant tank	E. Add proper regenerant to tank
	F. Control fails to draw in regenerant	F. Refer to Troubleshooting Guide number 12
	G. Insufficient regenerant level in regenerant tank	G. Check refill setting in programming. Check refill flow control for restrictions or debris and clean or replace
	H. Damaged seal/stack assembly	H. Replace seal/stack assembly
	I. Control valve body type and piston type mix matched	I. Verify proper control valve body type and piston type match
	J. Fouled media bed	J. Replace media bed
<b>9. Control valve uses too much regenerant</b>	A. Improper refill setting	A. Check refill setting
	B. Improper program settings	B. Check program setting to make sure they are specific to the water quality and application needs
	C. Control valve regenerates frequently	C. Check for leaking fixtures that may be exhausting capacity or system is undersized
<b>10. Residual regenerant being delivered to service</b>	A. Low water pressure	A. Check incoming water pressure – water pressure must remain at minimum of 25 psi
	B. Incorrect injector size	B. Replace injector with correct size for the application
	C. Restricted drain line	C. Check drain line for restrictions or debris and clean
<b>11. Excessive water in regenerant tank</b>	A. Improper program settings	A. Check refill setting
	B. Plugged injector	B. Remove injector and clean or replace
	C. Drive cap assembly not tightened in properly	C. Retighten the drive cap assembly
	D. Damaged seal/stack assembly	D. Replace seal/stack
	E. Restricted or kinked drain line	E. Check drain line for restrictions or debris and or unkink drain line
	F. Plugged backwash flow controller	F. Remove backwash flow controller and clean or replace
	G. Missing refill flow controller	G. Replace refill flow controller

<b>PROBLEM</b>	<b>CAUSE</b>	<b>CORRECTION</b>
<b>12. Control valve fails to draw in regenerant</b>	A. Injector is plugged	A. Remove injector and clean or replace
	B. Faulty regenerant piston	B. Replace regenerant piston
	C. Regenerant line connection leak	C. Inspect regenerant line for air leak
	D. Drain line restriction or debris cause excess back pressure	D. Inspect drain line and clean to correct restriction
	E. Drain line too long or too high	E. Shorten length and or height
	F. Low water pressure	F. Check incoming water pressure – water pressure must remain at minimum of 25 psi
<b>13. Water running to drain</b>	A. Power outage during regeneration	A. Upon power being restored control will finish the remaining regeneration time. Reset time of day. If PC board has battery back up present the battery may be depleted. See front cover and drive assembly drawing for instructions.
	B. Damaged seal/stack assembly	B. Replace seal/stack assembly
	C. Piston assembly failure	C. Replace piston assembly
	D. Drive cap assembly not tightened in properly	D. Retighten the drive cap assembly
<b>14. E1, Err – 1001, Err – 101 = Control unable to sense motor movement</b>	A. Motor not inserted full to engage pinion, motor wires broken or disconnected	A. Disconnect power, make sure motor is fully engaged, check for broken wires, make sure two pin connector on motor is connected to the two pin connection on the PC board labeled MOTOR. Press NEXT and REGEN buttons for 3 seconds to resynchronize software with piston position or disconnect power supply from PC board for 5 seconds and then reconnect.
	B. PC board not properly snapped into drive bracket	B. Properly snap PC board into drive bracket and then Press NEXT and REGEN buttons for 3 seconds to resynchronize software with piston position or disconnect power supply from PC board for 5 seconds and then reconnect.
	C. Missing reduction gears	C. Replace missing gears
<b>15. E2, Err – 1002, Err – 102 = Control valve motor ran too short and was unable to find the next cycle position and stalled</b>	A. Foreign material is lodged in control valve	A. Open up control valve and pull out piston assembly and seal/stack assembly for inspection. Press NEXT and REGEN buttons for 3 seconds to resynchronize software with piston position or disconnect power supply from PC board for 5 seconds and then reconnect.
	B. Mechanical binding	B. Check piston and seal/stack assembly, check reduction gears, check drive bracket and main drive gear interface. Press NEXT and REGEN buttons for 3 seconds to resynchronize software with piston position or disconnect power supply from PC board for 5 seconds and then reconnect.
	C. Main drive gear too tight	C. Loosen main drive gear. Press NEXT and REGEN buttons for 3 seconds to resynchronize software with piston position or disconnect power supply from PC board for 5 seconds and then reconnect.
	D. Improper voltage being delivered to PC board	D. Verify that proper voltage is being supplied. Press NEXT and REGEN buttons for 3 seconds to resynchronize software with piston position or disconnect power supply from PC board for 5 seconds and then reconnect.

# TROUBLESHOOTING GUIDE *cont'd*:

<b>PROBLEM</b>	<b>CAUSE</b>	<b>CORRECTION</b>
<b>16. E3, Err – 1003, Err – 103 = Control valve motor ran too long and was unable to find the next cycle position</b>	A. Motor failure during a regeneration	A. Check motor connections then Press NEXT and REGEN buttons for 3 seconds to resynchronize software with piston position or disconnect power supply from PC board for 5 seconds and then reconnect.
	B. Foreign matter built up on piston and stack assemblies creating friction and drag enough to time out motor	B. Replace piston and stack assemblies. Press NEXT and REGEN buttons for 3 seconds to resynchronize software with piston position or disconnect power supply from PC board for 5 seconds and then reconnect.
	C. Drive bracket not snapped in properly and out enough that reduction gears and drive gear do not interface	C. Snap drive bracket in properly then Press NEXT and REGEN buttons for 3 seconds to resynchronize software with piston position or disconnect power supply from PC board for 5 seconds and then reconnect.
<b>17. E4, Err – 1004, Err – 104 = Control valve motor ran too long and timed out trying to reach home position</b>	A. Drive bracket not snapped in properly and out enough that reduction gears and drive gear do not interface	A. Snap drive bracket in properly then Press NEXT and REGEN buttons for 3 seconds to resynchronize software with piston position or disconnect power supply from PC board for 5 seconds and then reconnect.
<b>18. Err -1006, Err – 106, Err - 116 = MAV/ SEPS/ NHBP/ AUX MAV valve motor ran too long and unable to find the proper park position</b>  <b>Motorized Alternating Valve = MAV</b>  <b>Separate Source = SEPS</b>  <b>No Hard Water Bypass = NHBP</b>  <b>Auxiliary MAV = AUX MAV</b>	A. Control valve programmed for ALT A or B, nHbP, SEPS, or AUX MAV with out having a MAV or NHBP valve attached to operate that function	A. Press NEXT and REGEN buttons for 3 seconds to resynchronize software with piston position or disconnect power supply from PC board for 5 seconds and then reconnect. Then reprogram valve to proper setting
	B. MAV/NHBP motor wire not connected to PC board	B. Connect MAV/NHBP motor to PC board two pin connection labeled DRIVE. Press NEXT and REGEN buttons for 3 seconds to resynchronize software with piston position or disconnect power supply from PC board for 5 seconds and then reconnect.
	C. MAV/NHBP motor not fully engaged with reduction gears	C. Properly insert motor into casing, do not force into casing Press NEXT and REGEN buttons for 3 seconds to resynchronize software with piston position or disconnect power supply from PC board for 5 seconds and then reconnect.
	D. Foreign matter built up on piston and stack assemblies creating friction and drag enough to time out motor	D. Replace piston and stack assemblies. Press NEXT and REGEN buttons for 3 seconds to resynchronize software with piston position or disconnect power supply from PC board for 5 seconds and then reconnect.
<b>19. Err – 1007, Err – 107, Err - 117 = MAV/ SEPS/NHBP/AUX MAV valve motor ran too short (stalled) while looking for proper park position</b>  <b>Motorized Alternating Valve = MAV</b>  <b>Separate Source = SEPS</b>  <b>No Hard Water Bypass = NHBP</b>  <b>Auxiliary MAV = AUX MAV</b>	A. Foreign material is lodged in MAV/NHBP valve	A. Open up MAV/NHBP valve and check piston and seal/ stack assembly for foreign material. Press NEXT and REGEN buttons for 3 seconds to resynchronize software with piston position or disconnect power supply from PC board for 5 seconds and then reconnect.
	B. Mechanical binding	B. Check piston and seal/stack assembly, check reduction gears, drive gear interface, and check MAV/NHBP black drive pinion on motor for being jammed into motor body. Press NEXT and REGEN buttons for 3 seconds to resynchronize software with piston position or disconnect power supply from PC board for 5 seconds and then reconnect.

# REPLACEMENT PARTS:

## FRONT COVER AND DRIVE ASSEMBLY

Item No.	Part No.	Description	Qty.
1	CV3367-01-A	Black cover	1
	CV3367-01-WR-A	Gray cover	1
2	CV3107-1	Motor	1
3	CV3106-1	Drive bracket & spring clip	1
4	CV3813WP	Evolve ES PC board	1
5	CV3110	Drive gear, 12 x 36	3
6	CV3109	Drive gear cover	1
7	CV3002CC	Drive assembly, CC	-
not shown	CV3186	Transformer, 110V-12V, AC (standard)	1
	CV3684-WR-GLD	<b>Optional</b> weather cover	1

**NOTE: Battery Location**

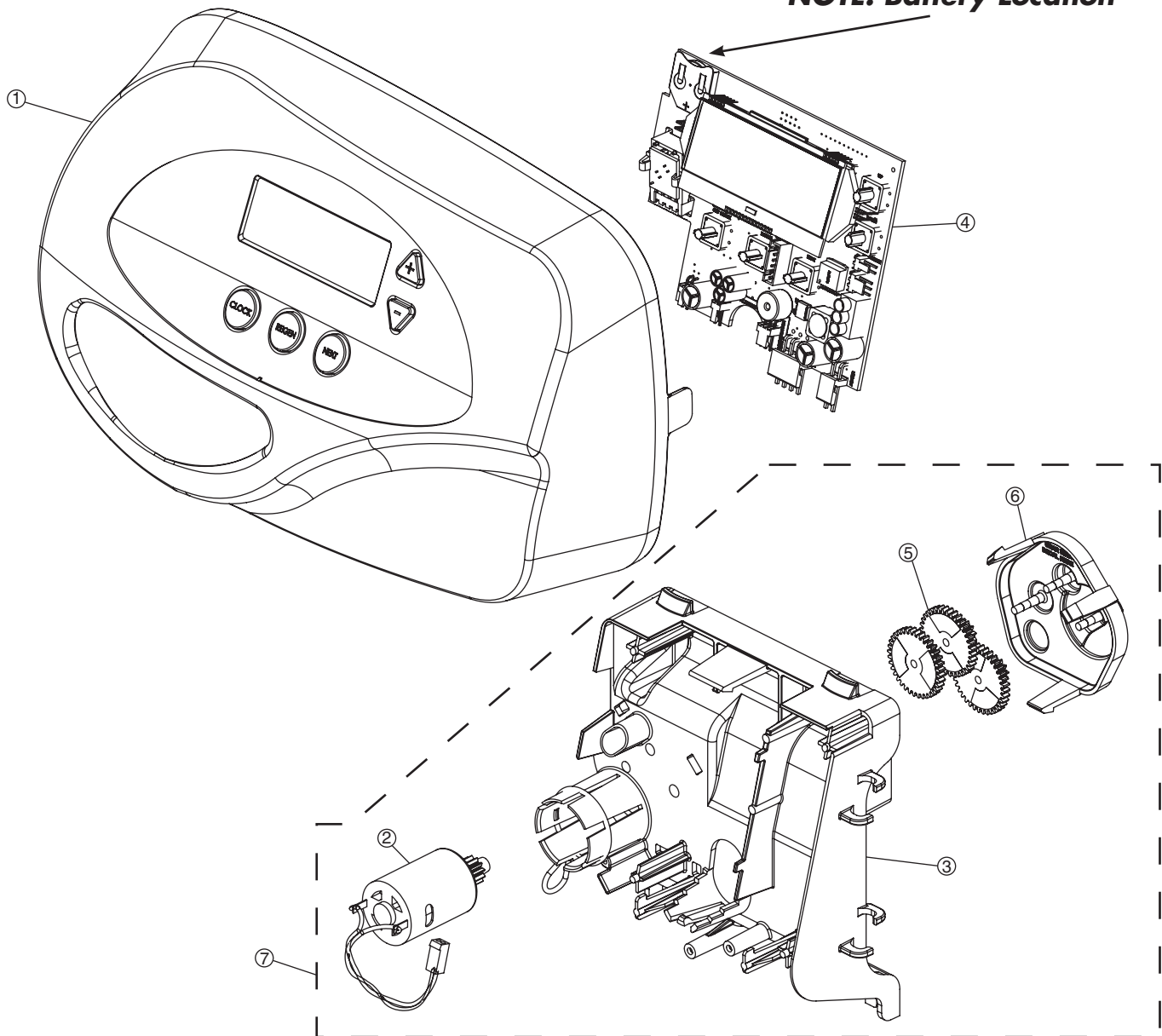

# REPLACEMENT PARTS:

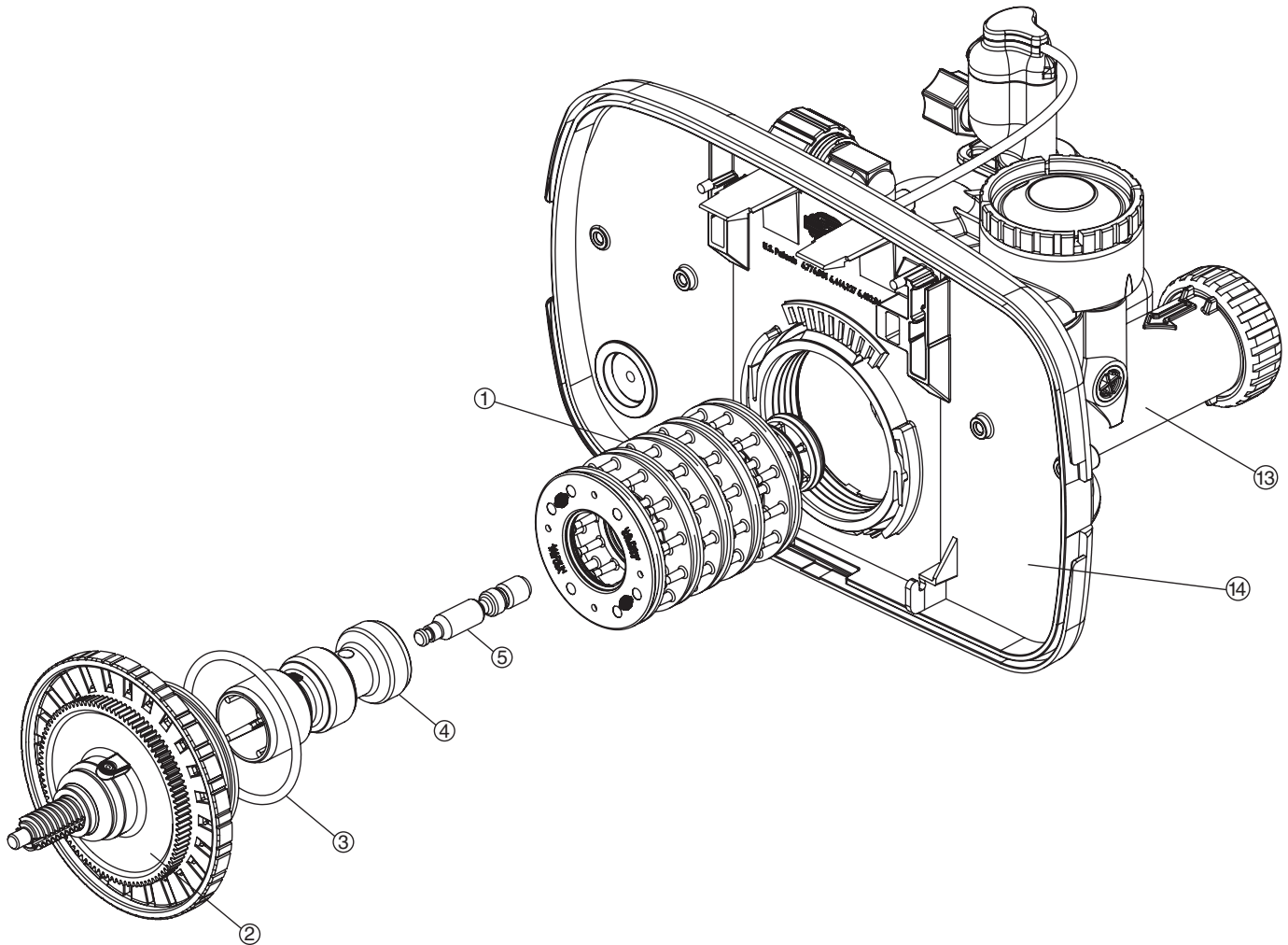

## PISTON ASSEMBLY

Item No.	Part No.	Description	Qty.
1	CV3005	1" spacer stack assembly	1
	CV3430	1.25" spacer stack assembly	1
2	CV3004	Drive cap assembly	1
3	CV3135	O-ring 228	1
4	CV3011	1" piston assembly downflow	1
	CV3011-01	1" piston assembly upflow	1
	CV3407	1.25" piston assembly downflow	1
5	CV3174	Regenerant piston	1
6	CV3180	O-ring 337	1
7	CV3105	O-ring 215	1
	CV3358	O-ring 219, 1.25" distributor	1
13	CV3001-04	1" body assembly downflow	1
	CV3001UP	1" body assembly upflow	1
	CV3020	1.25" body assembly downflow	1
14	CV3368	Drive backplate	1

# REPLACEMENT PARTS:

BYPASS VALVE			
Item No.	Part No.	Description	Qty.
1	CV3151	Nut, 1" quick connect	2
2	CV3150	Split ring	2
3	CV3105	O-ring 215	2
4	CV3145	Bypass rotor, 1"	2
5	CV3146	Bypass cap	2
6	CV3147	Bypass handle	2
7	CV3148	Bypass rotor seal retainer	2
8	CV3152	O-ring 135	2
9	CV3155	O-ring 112	2
10	CV3156	O-ring 214	2

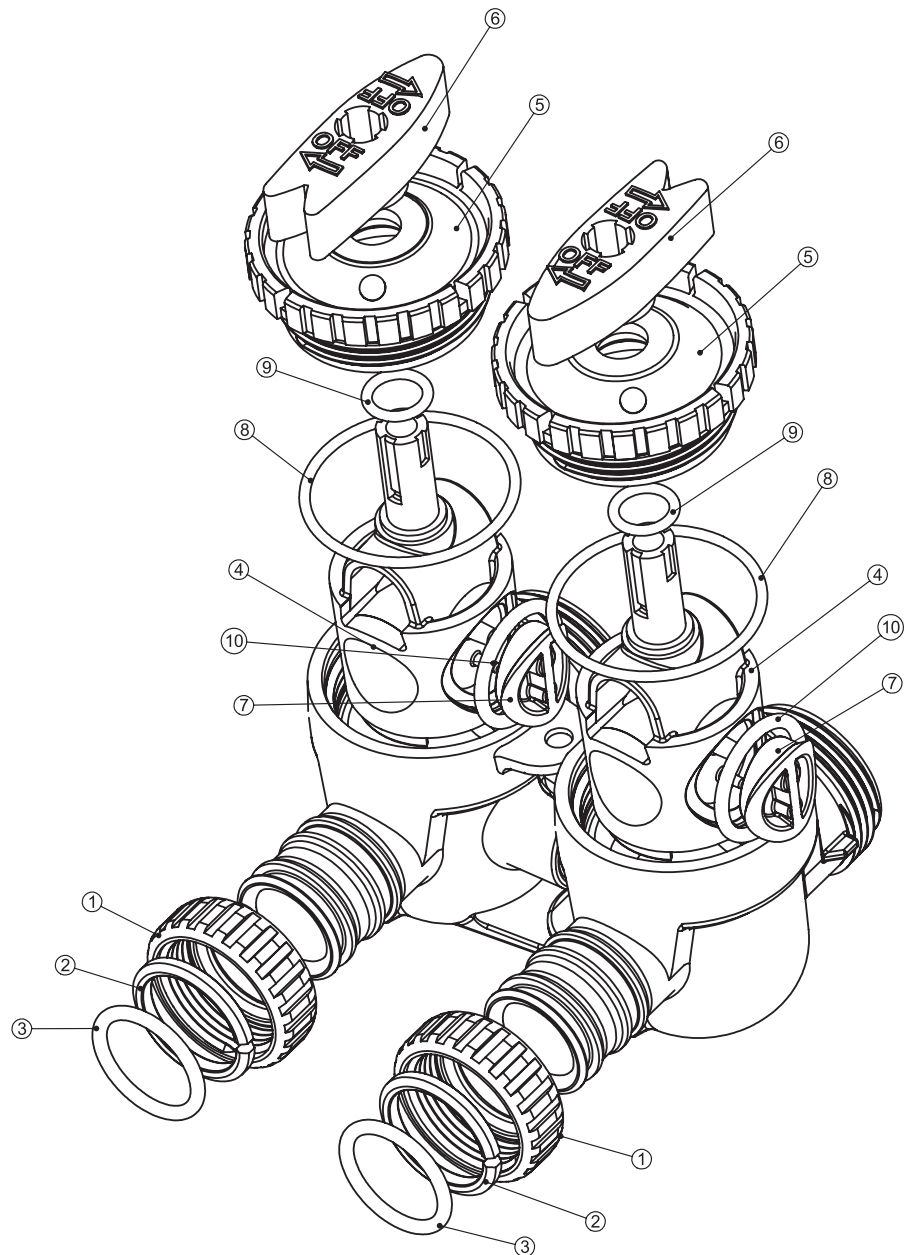

# REPLACEMENT PARTS:

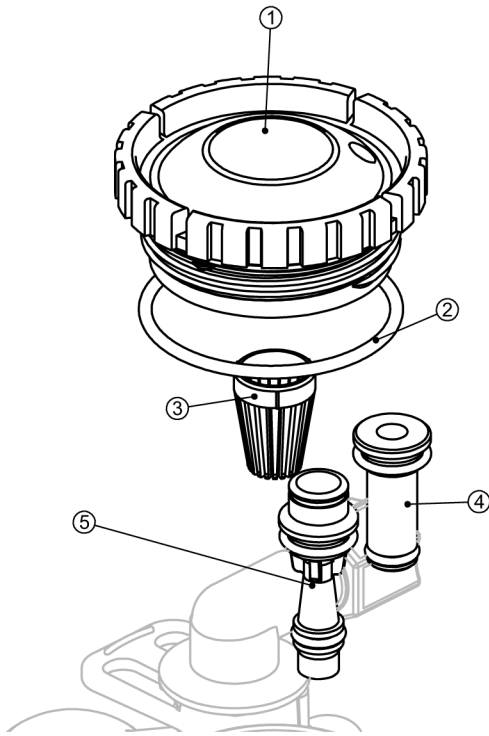

INJECTOR ASSEMBLIES			
Item No.	Part No.	Description	Qty.
1	CV3176	Injector cap	1
2	CV3152	O-ring 135	1
3	CV3177-01	Injector screen	1
4	CV3010-1Z	Injector assembly plug	1
5	CV3010-1A	<b>A</b> injector assembly, <b>BLACK</b>	1
	CV3010-1B	<b>B</b> injector assembly, <b>BROWN</b>	
	CV3010-1C	<b>C</b> injector assembly, <b>VIOLET</b>	
	CV3010-1D	<b>D</b> injector assembly, <b>RED</b>	
	CV3010-1E	<b>E</b> injector assembly, <b>WHITE</b>	
	CV3010-1F	<b>F</b> injector assembly, <b>BLUE</b>	
	CV3010-1G	<b>G</b> injector assembly, <b>YELLOW</b>	
	CV3010-1H	<b>H</b> injector assembly, <b>GREEN</b>	
	CV3010-1I	<b>I</b> injector assembly, <b>ORANGE</b>	
	CV3010-1J	<b>J</b> injector assembly, <b>LIGHT BLUE</b>	
CV3010-1K	<b>K</b> injector assembly, <b>LIGHT GREEN</b>		
not shown	CV3170	O-ring 011, lower	*
not shown	CV3171	O-ring 013, upper	*

\* The injector plug and the injector each use one lower and one upper o-ring

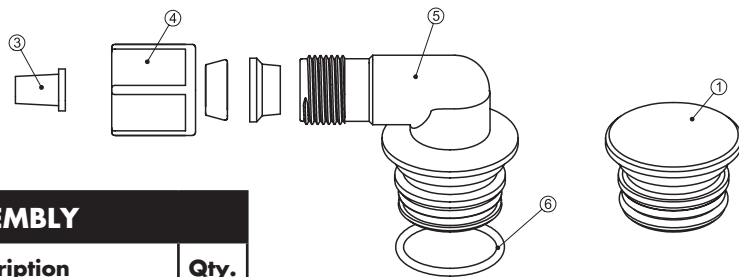

BRINE ELBOW ASSEMBLY			
Item No.	Part No.	Description	Qty.
1	CV3195-01	Refill port plug assembly	1
2	CH4615	Elbow locking clip	1
3	CS1197	Tube insert, 3/8"	1
4	CJCPG-6PBLK	Nut, 3/8"	1
5	CH4613	Elbow cap, 3/8"	1
6	CV3163	O-ring 019	1

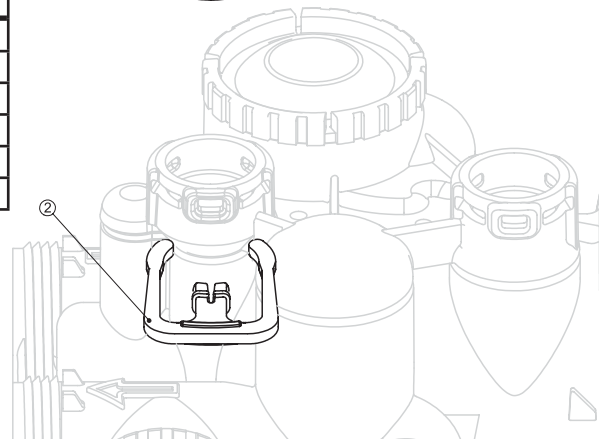

# REPLACEMENT PARTS:

## DRAIN LINE ASSEMBLY 3/4"

Item No.	Part No.	Description	Qty.
1	CH4615	Elbow locking clip	1
2	CPKP10TS8-BULK	<i>Optional</i> insert, 5/8" tube	1
3	CV3192	<i>Optional</i> nut, 3/4" drain elbow	1
4	CV3158-02	Drain elbow, 3/4" NPT with O-ring	1
5	CV3163	O-ring 019	1
6	CV3159-01	DLFC retainer assembly	1
7	CV3162-007	0.7 DLFC for 3/4" elbow	1
	CV3162-010	1.0 DLFC for 3/4" elbow	
	CV3162-013	1.3 DLFC for 3/4" elbow	
	CV3162-017	1.7 DLFC for 3/4" elbow	
	CV3162-022	2.2 DLFC for 3/4" elbow	
	CV3162-027	2.7 DLFC for 3/4" elbow	
	CV3162-032	3.2 DLFC for 3/4" elbow	
	CV3162-042	4.2 DLFC for 3/4" elbow	
	CV3162-053	5.3 DLFC for 3/4" elbow	
	CV3162-065	6.5 DLFC for 3/4" elbow	
CV3162-075	7.5 DLFC for 3/4" elbow		
CV3162-090	9.0 DLFC for 3/4" elbow		
CV3162-100	10.0 DLFC for 3/4" elbow		
8	CV3331	Drain elbow and retainer assembly	

Items 2 and 3, nut and insert are only used with 1/2" I.D. by 5/8" O.D. polytubing. For other piping material, the 3/4" NPT is used.

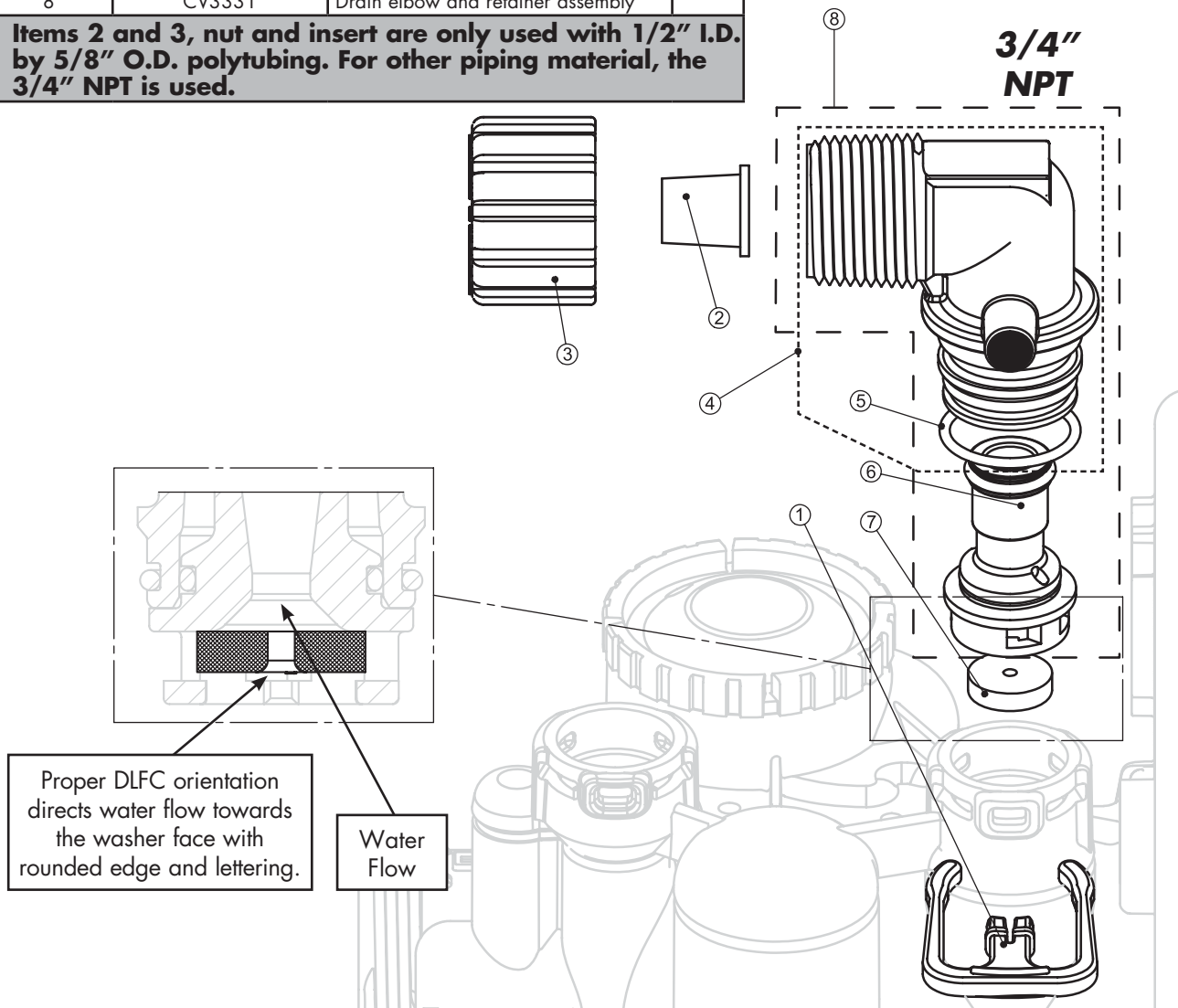

# REPLACEMENT PARTS:

WATER METER & METER PLUG			
Item No.	Part No.	Description	Qty.
1	CV3151	Nut, 1" QC	1
2	CV3003	Meter assembly, includes items 3 & 4	1
3	CV3118-01	Turbine assembly	1
4	CV3105	O-ring 215	1
5	CV3003-01	Meter plug assembly	1
6	CV3013	<i>Optional</i> mixing valve	1

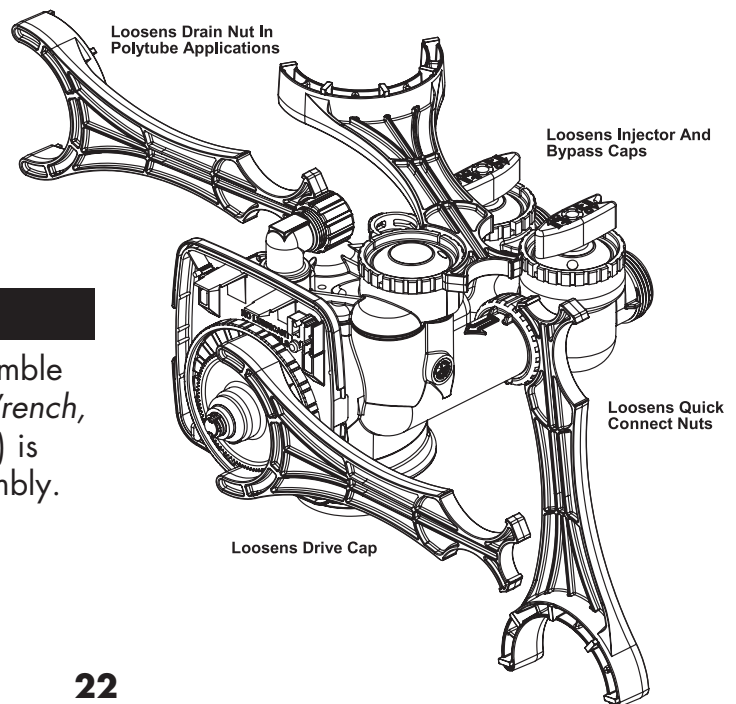
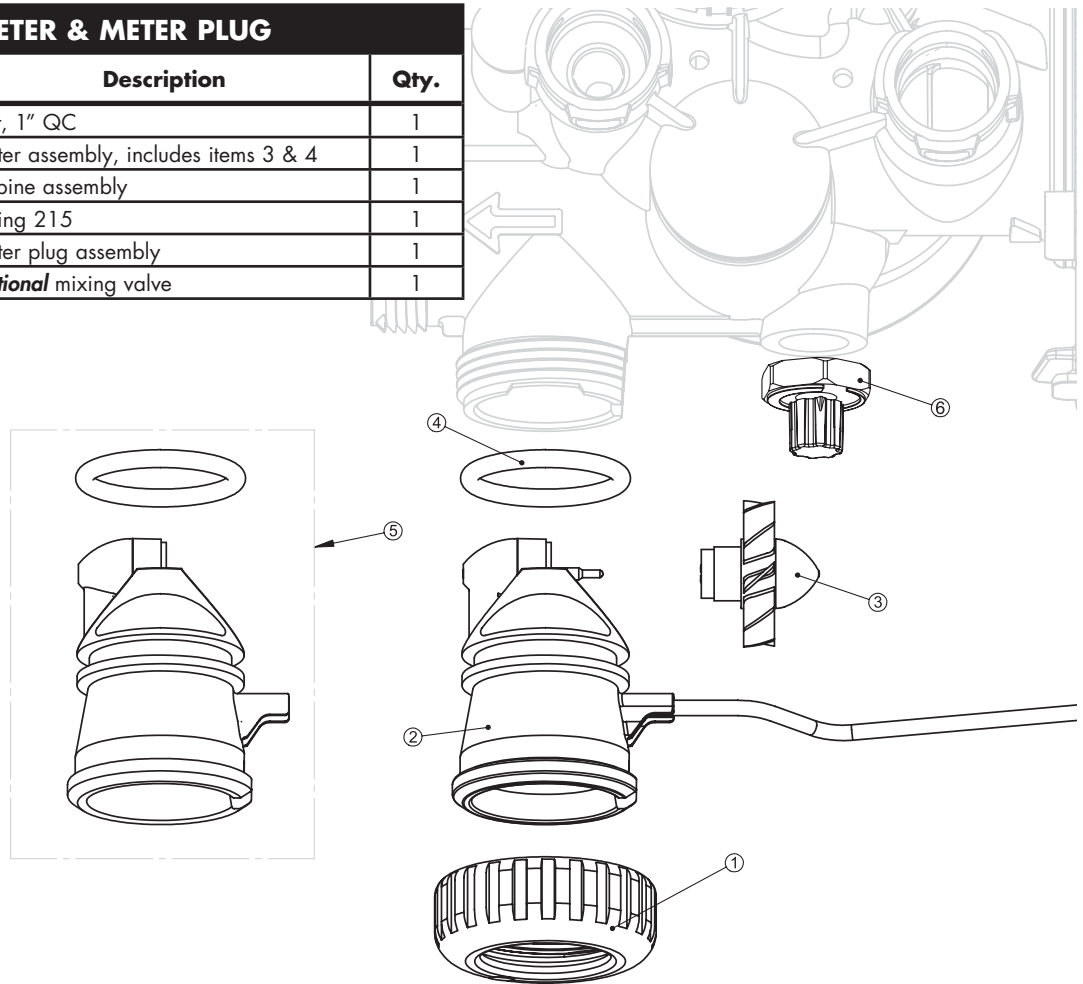

## SERVICE WRENCH - CV3193-02

Although no tools are necessary to assemble or disassemble the valve, the *Service Wrench*, (shown in various positions on the valve) is available to aid in assembly or disassembly.

# REPLACEMENT PARTS:

## BRINE TANK ASSEMBLY

Item No.	Part No.	Description	Qty.
1	CG2191-92	Brine tank cover, injection molded Evolve	1
	CG2180	Brine tank cover, standard	1
2	CH1095-01	<b>Optional</b> 18" diameter salt grid	1
	CH1080	<b>Optional</b> 24" diameter salt grid	1
3	CG21833CB1C00	18" x 33" brine tank, black	1
	CG21840CB1C00	18" x 40" brine tank, black	1
	CG22441CB1C00	24" x 41" brine tank, black	1
4	CH1030-27	4" x 27" brine well (18 x 33 BT)	1
	CH1030-34.5	4" x 34.5" brine well (18 x 40, 24 x 40 BT's)	1
5	CH1018	2 piece overflow set	1
6	CH4500-48	474 air check assembly, 1/2" x 48"	1
7	CH4640-32	474 float assembly, 32" w/ 2 grommets	1
8	CH4600-50	474 safety brine valve w/ .5 gpm glow control	1
9	CH7016	Cap 4" brine well	1
10	CH4626	Nut safety brine valve stand off	1
<b>ASSEMBLIES</b>			
11	CH4700-29WR-1	.5 gpm safety float assembly, 18" x 33"	
	CH4700-36.5WR-1	.5 gpm safety float assembly, 18" x 40"	

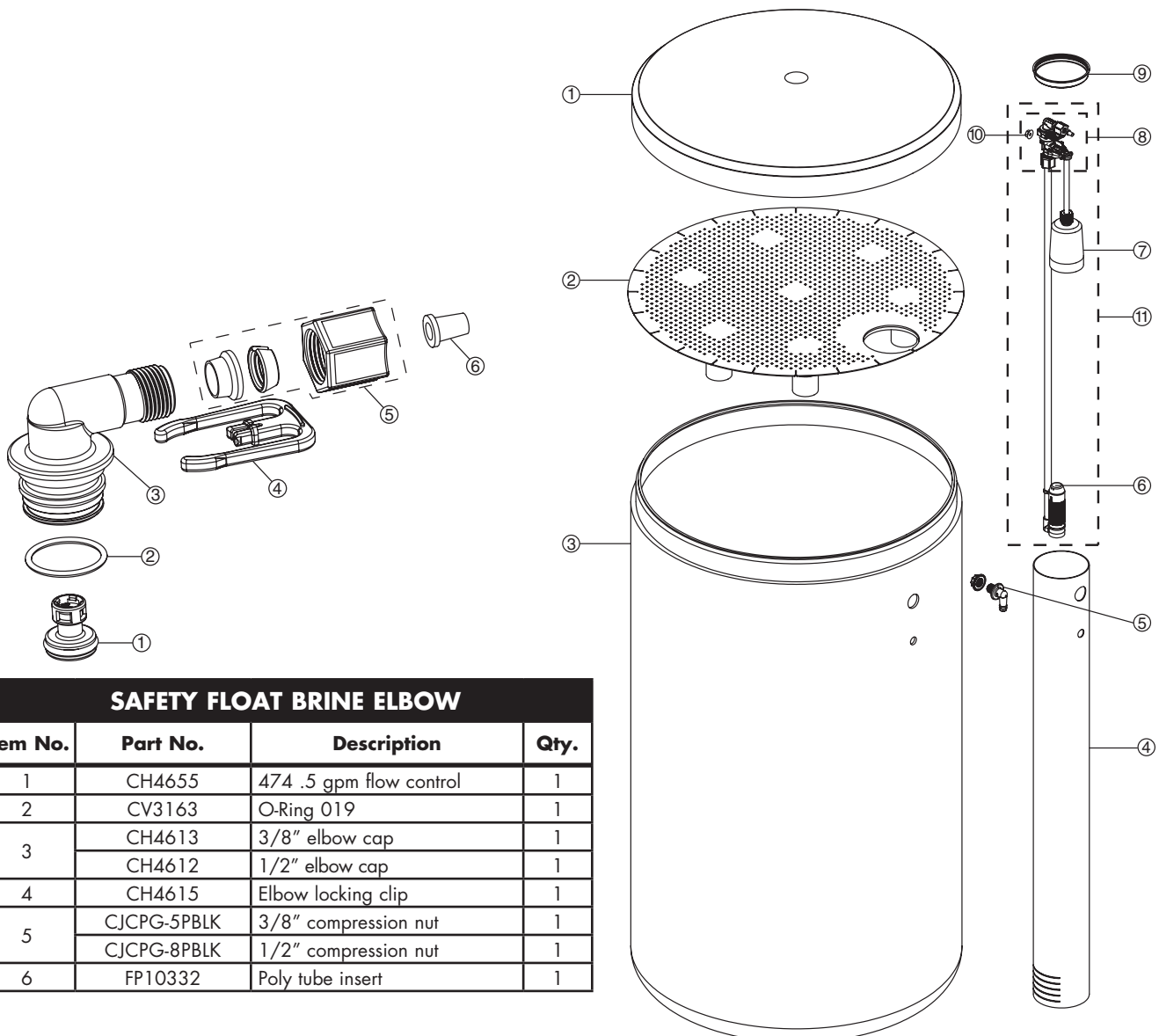

## SAFETY FLOAT BRINE ELBOW

Item No.	Part No.	Description	Qty.
1	CH4655	474 .5 gpm flow control	1
2	CV3163	O-Ring 019	1
3	CH4613	3/8" elbow cap	1
	CH4612	1/2" elbow cap	1
4	CH4615	Elbow locking clip	1
5	CJCPG-5PBLK	3/8" compression nut	1
	CJCPG-8PBLK	1/2" compression nut	1
6	FP10332	Poly tube insert	1

# INSTALLATION FITTING ASSEMBLIES:

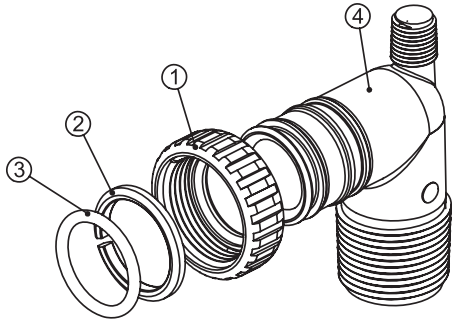

## 1" PVC MALE NPT ELBOW

Item No.	Part No.	Description	Qty.
	CV3007	1" PVC male NPT elbow assembly	2
1	CV3151	Nut, 1" quick connect	2
2	CV3150	Split ring	2
3	CV3105	O-ring 215	2
4	CV3149	Fitting	2

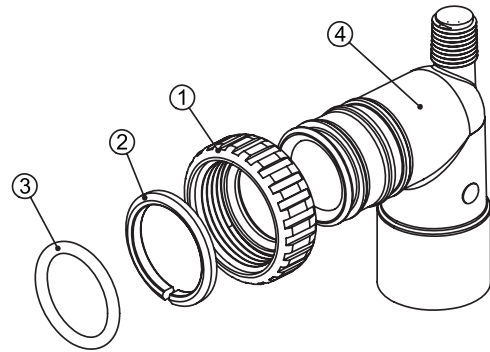

## 3/4" & 1" PVC SOLVENT ELBOW

Item No.	Part No.	Description	Qty.
	CV3007-01	3/4" & 1" PVC solvent elbow assembly	2
1	CV3151	Nut, 1" quick connect	2
2	CV3150	Split ring	2
3	CV3105	O-ring 215	2
4	CV3189	Fitting	2

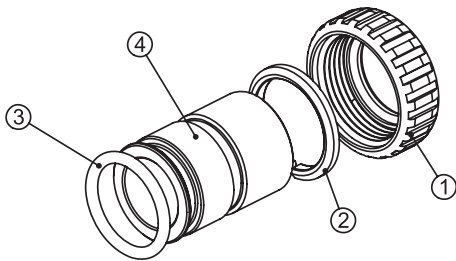

## 1" BRASS SWEAT

Item No.	Part No.	Description	Qty.
	CV3007-02	1" brass sweat assembly	2
1	CV3151	Nut, 1" quick connect	2
2	CV3150	Split ring	2
3	CV3105	O-ring 215	2
4	CV3188	Fitting	2

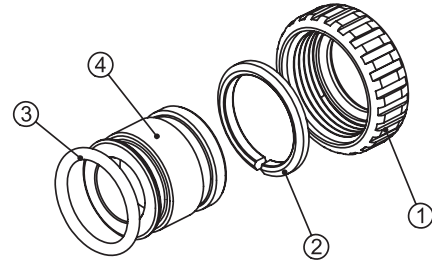

## 3/4" BRASS SWEAT

Item No.	Part No.	Description	Qty.
	CV3007-03	3/4" brass sweat assembly	2
1	CV3151	Nut, 1" quick connect	2
2	CV3150	Split ring	2
3	CV3105	O-ring 215	2
4	CV3188-01	Fitting	2

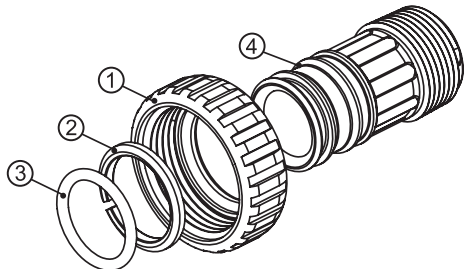

## 1" PLASTIC MALE NPT

Item No.	Part No.	Description	Qty.
	CV3007-04	1" plastic male NPT assembly	2
1	CV3151	Nut, 1" quick connect	2
2	CV3150	Split ring	2
3	CV3105	O-ring 215	2
4	CV3164	Fitting	2

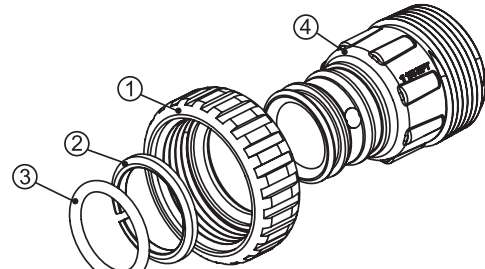

## 1-1/4" PLASTIC MALE

Item No.	Part No.	Description	Qty.
	CV3007-05	1-1/4" plastic male assembly	2
1	CV3151	Nut, 1" quick connect	2
2	CV3150	Split ring	2
3	CV3105	O-ring 215	2
4	CV3317	Fitting	2

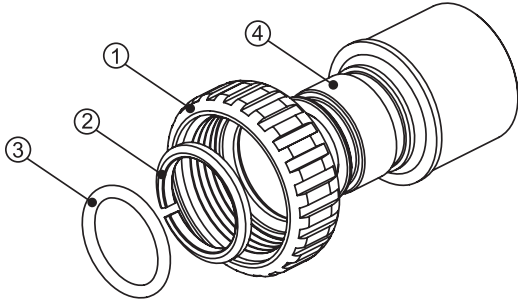

<b>1-1/4" &amp; 1-1/2" BRASS SWEAT</b>			
Item No.	Part No.	Description	Qty.
	CV3007-09	1-1/4 & 1-1/2" brass sweat assembly	2
1	CV3151	Nut, 1" quick connect	2
2	CV3150	Split ring	2
3	CV3105	O-ring 215	2
4	CV3375	Fitting	2

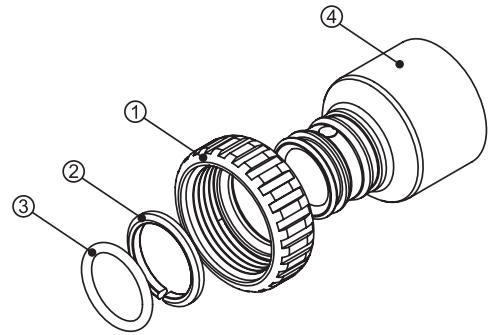

<b>1-1/4" &amp; 1-1/2" PVC SOLVENT</b>			
Item No.	Part No.	Description	Qty.
	CV3007-07	1-1/4" & 1-1/2" PVC solvent assembly	2
1	CV3151	Nut, 1" quick connect	2
2	CV3150	Split ring	2
3	CV3105	O-ring 215	2
4	CV3352	Fitting	2

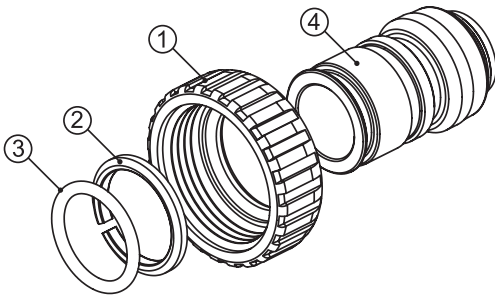

<b>3/4" BRASS SHARK BITE</b>			
Item No.	Part No.	Description	Qty.
	CV3007-12	3/4" brass Shark Bite assembly	2
1	CV3151	Nut, 1" quick connect	2
2	CV3150	Split ring	2
3	CV3105	O-ring 215	2
4	CV3628	Fitting	2

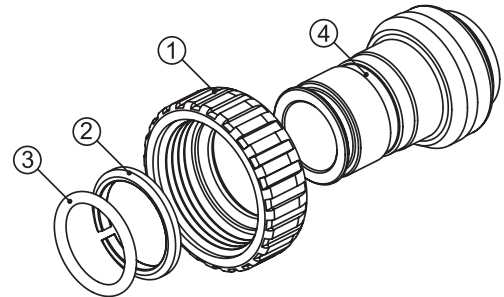

<b>1" BRASS SHARK BITE</b>			
Item No.	Part No.	Description	Qty.
	CV3007-13	1" brass Shark Bite assembly	2
1	CV3151	Nut, 1" quick connect	2
2	CV3150	Split ring	2
3	CV3105	O-ring 215	2
4	CV3629	Fitting	2

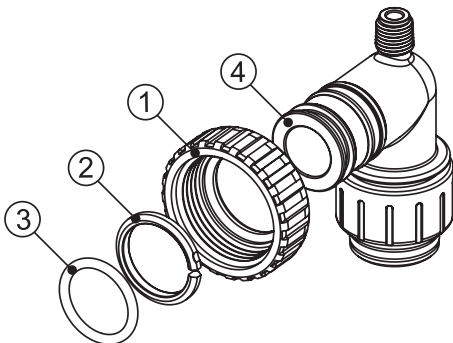

<b>3/4" JOHN GUEST ELBOW</b>			
Item No.	Part No.	Description	Qty.
	CV3007-15	3/4" John Guest elbow assembly	2
1	CV3151	Nut, 1" quick connect	2
2	CV3150	Split ring	2
3	CV3105	O-ring 215	2
4	CV3790	Fitting	2

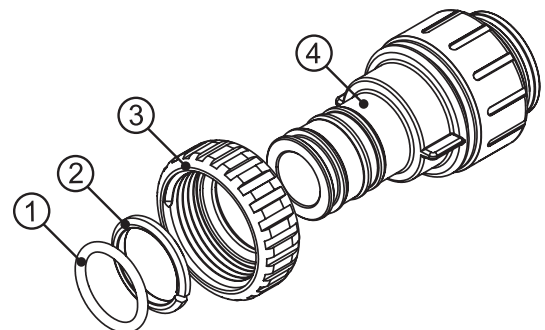

<b>1" JOHN GUEST</b>			
Item No.	Part No.	Description	Qty.
	CV3007-17	1" John Guest elbow assembly	2
1	CV3151	Nut, 1" quick connect	2
2	CV3150	Split ring	2
3	CV3105	O-ring 215	2
4	CV4045	Fitting	2

# PERFORMANCE DATA SHEET:

MODEL		ES-844	ES-948	ES-1044	ES-1054	ES-1248	ES-1354
Rated Softener Capacity:* (Grains/Lbs. Salt)	Minimum	13,700 @ 3.4	18,200 @ 4.5	18,200 @ 4.5	27,600 @ 7.0	36,400 @ 9.0	45,800 @ 11.5
	Medium	16,800 @ 6.0	23,500 @ 9.0	23,500 @ 9.0	36,700 @ 15.0	47,000 @ 18.0	53,900 @ 18.0
	Maximum	18,800 @ 8.0	28,000 @ 15.0	28,000 @ 15.0	42,000 @ 22.5	56,100 @ 30.0	69,800 @ 37.0
Efficiency at 1 lb Salt Setting (Grains/Lbs Salt)		4,042/1	4,042/1	4,042/1	4,042/1	4,042/1	4,042/1
Max. Service Flow Rate (GPG)		11.7	13.1	16.0	13.3	16.4	17.1
Max. Pressure Loss at Max. Service (PSI)		15	15	15	15	15	15
Min. to Max. Working Pressure (PSI)		30-100	30-100	30-100	30-100	30-100	30-100
Min. to Max. Operating Temperature (°F)		33-100	33-100	33-100	33-100	33-100	33-100
Max. Flow to Drain During Regeneration (GPM)		1.3	1.7	2.2	2.2	3.2	3.2
Amount of High Capacity Cat-ion Resin (Cu. Ft.)		.75	1.0	1.0	1.5	2.0	2.5
Electrical Requirements (volts-hertz)		110-50/60	110-50/60	110-50/60	110-50/60	110-50/60	110-50/60
Pipe Size		1"	1"	1"	1"	1"	1"
Total Dimensions:	Media Tank and Valve	8"W x 52"H	9"W x 56"H	10"W x 52"H	10"W x 62"H	12"W x 56"H	13"W x 62"H
	Brine Tank	18"W x 33"H	18"W x 33"H	18"W x 33"H	18"W x 33"H	18"W x 40"H	18"W x 40"H

\*All Evolve ES water softeners are set at "medium salting" from the factory.

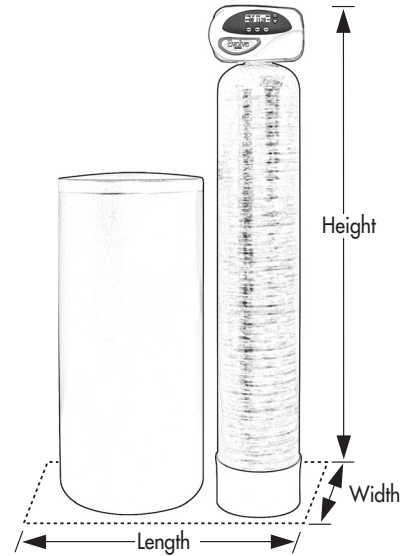



## Evolve Series® Water Conditioner Limited Warranty

Congratulations. You have purchased one of the finest water treatment systems available. In the unlikely event of a problem due to defects in material and workmanship, Water-Right® proudly warrants our Evolve Series® water conditioners to the original owner, at original installation location, when installed in accordance with Water-Right specifications from the date of original installation as follows:

- For the LIFETIME of the original owner:** Media tank, except for damages due to freezing, high pressure (120 PSI and above), extreme temperature (100° F and above) or a vacuum on the system.
- For a period of TEN YEARS:** Brine tank.
- For a period of FIVE YEARS:** Complete valve.
- For a period of ONE YEAR:** All other parts and components.

Any part found defective within the terms of this warranty will be repaired or replaced by the dealer at the manufacturer's discretion. You pay only freight from our factory and local dealer charges. To obtain local warranty service, contact original dealer. If original dealer is unknown, contact Water-Right for authorized service dealer in your area. If no authorized dealer is located in your area, please ship defective part or component freight prepaid to:

Water-Right, Inc.  
1900 Prospect Ct.  
Appleton, Wisconsin 54914

Water-Right, at its discretion, will repair or replace the part or component at its expense and return part freight collect.

The above provisions of the warranty are valid as long as the unit is connected in compliance with local plumbing codes and in an equivalent manner and condition of the original installation and is owned by the original owner.

This warranty does not cover expendable or misapplied medias, or damages due to accident, fire, flood, freezing, or any other Act of God. Water-Right is not responsible for damages due to change in water conditions, misapplication, misuse, neglect, vacuum, oxidizing agents, alteration, or lack of maintenance. No responsibility is assumed for loss of use of the unit, inconvenience, loss or damage to real or personal property or any incidental or consequential damages. Furthermore, we assume no liability and extend no warranties, express or implied, for the use of this product with a non-potable water source. **To the extent permitted by law, Water-Right disclaims all implied warranties, including without limitation warranties of merchantability and fitness for particular purpose; to the extent required by law, any such implied warranties are limited in duration to the period specified above for the specified components.**

Some states do not allow limitations on how long an implied warranty lasts, so the above limitation may not apply to you. Some states do not allow the exclusion or limitation of incidental or consequential damages, so the above limitation or exclusion may not apply to you. This warranty gives you specific legal rights, and you may also have other rights which vary from state to state.

# QUICK REFERENCE GUIDE:

## GENERAL OPERATION

When the system is operating, one of three displays will be shown: time of day, gallons of treated water available, or gallons per minute. Pressing **NEXT** will toggle between the three choices.

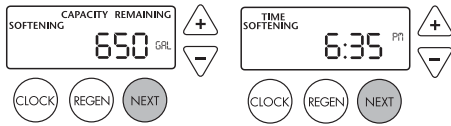

## TO SET TIME OF DAY

In the event of a prolonged power outage, time of day flashes, indicating that this needs to be reset. All other information will be stored in memory no matter how long the power outage. Please complete the steps as shown to the right. To access this mode, press **CLOCK**.

1. Accessed by pressing **CLOCK**
2. Adjust hours with **+** and **-** buttons, AM/PM toggles at 12
3. Press **NEXT**
4. Adjust minutes with **+** and **-** buttons
5. Press **NEXT** to complete and return to normal operation

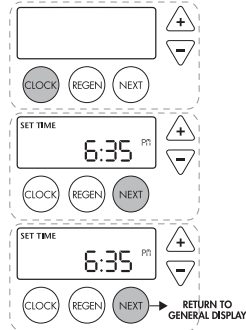

## ADJUST HARDNESS, DAYS BETWEEN REGENERATION, OR TIME OF REGENERATION

For initial set-up or to make adjustments, please complete the steps as shown to the right. Access this mode by pressing **NEXT** and **+** button simultaneously.

**NOTE:** Hardness display shows "nA-" if used as a filter. If other displays do not appear, refer to manual.

1. Accessed by pressing **NEXT** and **+** button simultaneously
2. Adjust hardness using **+** and **-** buttons
3. Press **NEXT**
4. Adjust days between regenerations using **+** and **-** buttons
5. Press **NEXT**
6. Adjust time of regeneration hour with **+** and **-** buttons, AM/PM toggles at 12
7. Press **NEXT**
8. Adjust time of regeneration minutes with **+** and **-** buttons
9. Adjust backlight setting with **+** and **-** buttons
10. Press **NEXT** to complete and return to normal operation

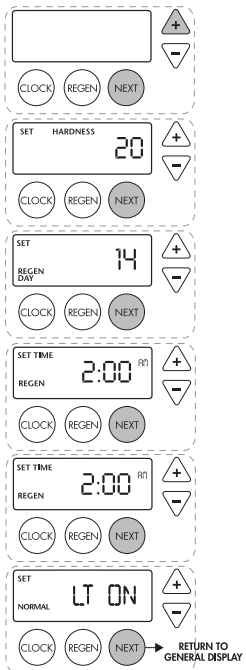

## MANUAL REGENERATION

**NOTE:** For softeners, if brine tank does not contain salt, fill with salt and wait at least two hours before regeneration. If you need to initiate a manual regeneration, either immediately, or the same night at the preprogrammed time for regeneration (typically 2:00 AM), complete the following steps.

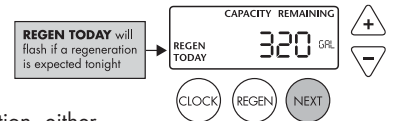

### For Immediate Regeneration:

Press and hold **REGEN** until valve motor starts (typically 5 seconds).

### For Regeneration the same night:

Press and release **REGEN** (notice that flashing "REGEN TODAY" appears).

## ERROR

If the display toggles between "Error" and an error code (i.e. a number), call a service technician and report the error code.

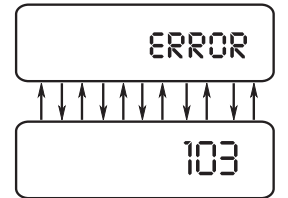

## BYPASS VALVE OPERATION

To shut off water to the system, position arrow handles as shown in the bypass operation diagram below. If your valve doesn't look like the diagram below, contact your service technician for instructions on how to shut off water.

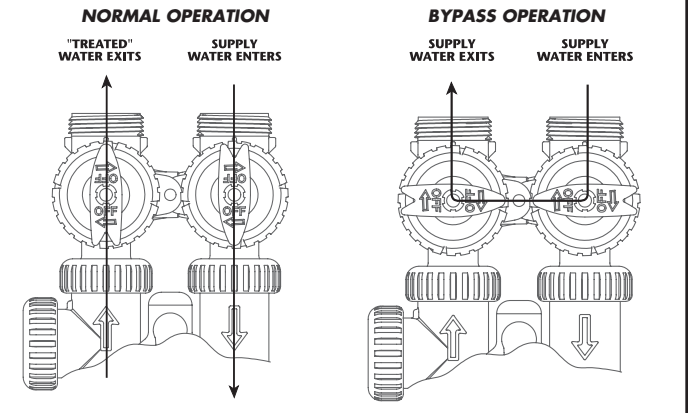

Manufactured exclusively for Evolve Series Dealers at:  
1900 Prospect Court • Appleton, WI 54914  
Phone: 920-739-9401 • Fax: 920-739-9406